

OPTICAL 1TM

Automatic level / Optical level / Dumpy Level
Instruction Manual



www.level1lasers.com.au

Contents

Introduction	2
Diagram	3
Operation Instruction	4
Calibration Self-Check	5
Technical Specifications	6
Maintenance	7

Introduction

Congratulations on buying the Optical 1™ Automatic Level/ Optical Level/ Dumpy Level.

The Optical 1™ features 20 x optical magnification, magnetic compensating and auto leveling, shake proof design, is sealed for superior dustproof and waterproof protection and comes with its own protective case.



Diagram



- 1. Bubble vial observation
- 2. Rough leveling bubble vial
- 3. Eyepiece
- 4. Graduated circle
- 5. Leveling knob

- 6. Graduated circle indication
- 7. Base
- 8. Horizontal fine adjustment knob
- 9. Objective lens
- 10. Focusing knob

Operating Instructions

Installation and Leveling

- Set tripod to shoulder height with the legs well spread and pushed firmly into the ground, so as to ensure the tripod creates a firm platform for your level.
- Place the instrument on the tripod and connect with the central screw.
- Center the bubble vial using the leveling knobs.

Aiming and Focusing

- Rotate eyepiece of the telescope (to focus the crosshair in the telescope) while looking through the eyepiece.
- Aim at the staff by looking along the rough finder on the top of the level.
- Rotate the focusing knob until view of staff is clear.
- Rotate the horizontal fine adjustment knob to align the staff in the center your view.

Staff Reading

- Looking at the staff, read the height from the middle line on the crosshair (Figure 1 is 3.345m)
- The distance between the two readings of the upper line and the lower line intersecting the vertical X a multiplication factor of 100 gives the distance from the tripod to the staff (upper hair reading-lower hair reading) $\times 100$. Figure 2 is $(3.653-3.039)\times 100=61.4\text{m}$

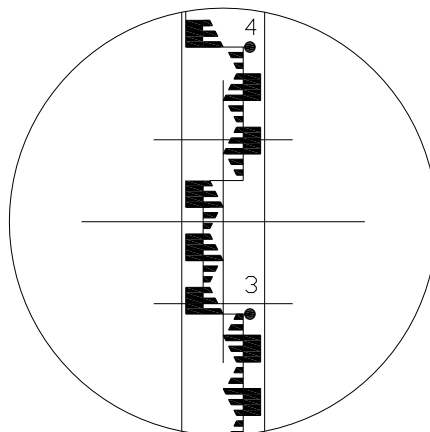

Figure 1

Calibration Self-Check

Check Bubble Vial

Set the instrument on tripod and adjust foot screws until circular bubble is centered. Rotate the instrument 180° to ensure the bubble remains centered.

*** So long as half of the bubble remains inside the circle the compensator will level.

Check auto leveling compensation

Select a flat ground with 45 to 60m in length, divide it in 3 parts with the same length (figure 4), set leveling staff on points B&C, and set the instrument on points A &D.

Set the instrument on point A, take the readings b1, c1 on the two leveling staffs respectively.

Then set the instrument on point D, take the readings b2, c2 on the two leveling staffs respectively.

If $\Delta = (b2 - c2) - (b1 - c1) \leq \pm 3\text{mm}$, the angle i is within tolerance.

Please return the laser to Level1Lasers if recalibration is required

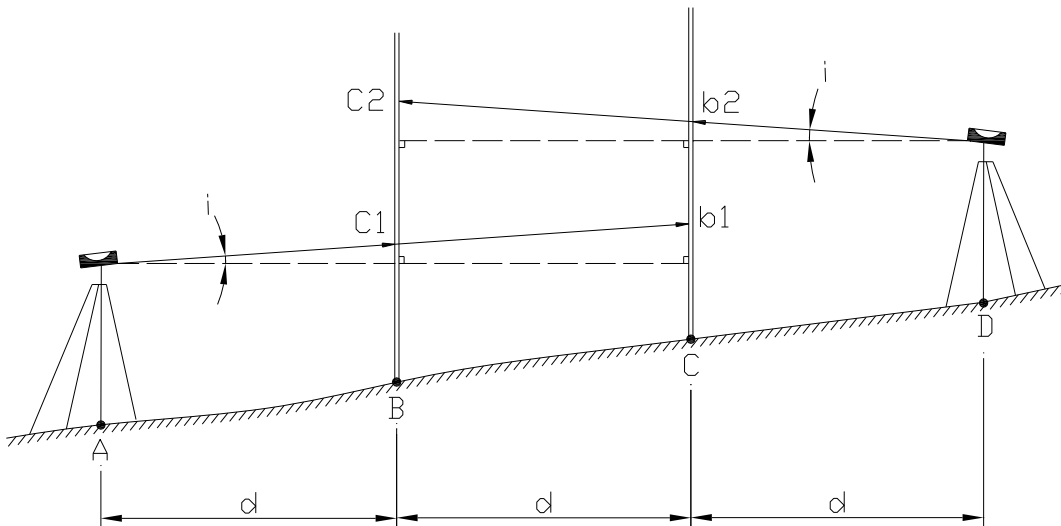

Figure 4

Technical Specifications

Telescope	Erect
Magnification	20x
Standard deviation of 1KM double-run leveling	2.5mm
Objective aperture mm	30
Field angle	1°20′
Shortest focusing distance	0.8m
Multiplication factor	100
Additive constant	0
Compensator working range	±15′
Compensator leveling accuracy	±0.8"
Sensitivity of circular bubble	8′ /2mm
Graduation interval	1°

Maintenance

Level1Lasers recommends that the Optical1™ is always stored in the protective case.

Keep the Optical1™ clean. Remove dust by gently wiping with a soft clean cloth. The Optical1™ is a precision measuring device and will provide many years of accurate measurements providing it is not subjected to excessive forces such as dropping or shaking.

Level1lasers recommends that you test the level for accuracy on a regular basis. If servicing is required, please contact your nearest Level1lasers stockist.

The Optical1™ should not be immersed in water or left outdoors in extreme weather conditions.

Warranty – 1 Year

This warranty does not cover damage or defects caused by or resulting from misuse, accidental damage, unauthorized repair, abnormal use or calibration after dispatch. This level has been calibrated prior to dispatch and through normal use should not go out of calibration. However, Level1lasers recommend that you check your equipment for calibration from time to time as units may go out of calibration with excessive vibration or after drops or knocks. Simple guides to checking calibration are outlined within the instruction manual of each unit.

**For further warranty information please visit
www.level1lasers.com.au**